



Rev3 15.12.23

RAINWATER HARVESTING SYSTEM

ECODEPUR[®] AQUAPLUVIA

RAINWATER HARVESTING SYSTEMS (SAAP AQUAPLUVIA)

The **rainwater systems ECODEPUR® AQUAPLUVIA** allow treatment and storage of rainwater, for reuse purposes, according to the Portuguese regulations.

The different SAAP ECODEPUR® AQUAPLUVIA systems are based on the technical specifications of ANQIP (Portuguese Association for the Quality of Building Installations), namely the Technical Specification ANQIP ETA 0701, which establishes the technical criteria for rainwater harvesting from roofs for non-potable purposes, as well as Decreto-Lei 119/2019.

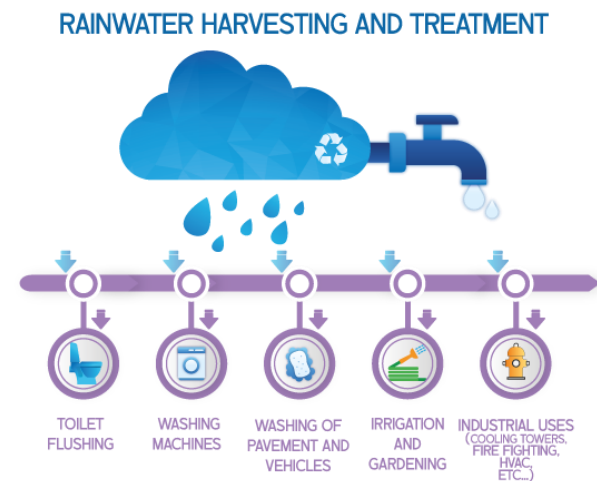

The **rainwater** can be **used** in:

- Toilet flushing
- Washing machines (the washing of clothes using rainwater does not need any special treatment, as long as the washing is made at temperatures of at least 55°C)
- Washing of pavements and vehicles
- Irrigation and gardening
- Industrial Uses (cooling towers, fire fighting networks, HVAC, etc)

According to Decreto-Lei 119/2019 – ANNEX 1, Table 1.a, the treated water is considered as Class A, allowing its use in toilet flushing, irrigation, pavement washing, firefighting reserves, among others.

QUALITY CLASS	BOD ₅ (mg/l O ₂)	TSS (mg/l)	TURBIDITY (NTU)	E. COLI (UFC/100 ml)	AMMONIACAL NITROGEN (mg NH ₄ ⁺ /l) ⁽¹⁾
CLASS A	≤ 10	≤ 10	≤ 5	≤ 10	≤ 10

RAINWATER SYSTEMS (SAAP)

SAAP/AQUAPLUVIA systems develop a full range of equipment for reducing the domestic potable water consumption, resulting in effective contribution to the preservation of the resource "water", as well as an advantageous economic return.

This system can be easily installed during construction phase, and its installation can also be an advantageous upgrade during refurbishment and/or rehabilitation phases.

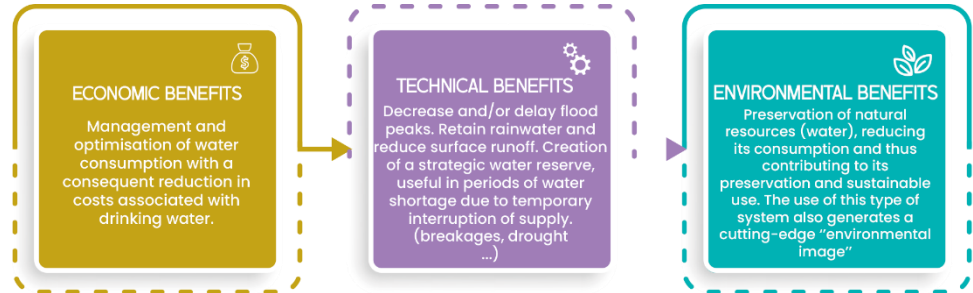

The hydraulic and sanitary dimensioning of the **AQUAPLUVIA systems (SAAP)** is carried out according to the method prescribed in the **ANQIP Technical Specification ETA 0701**, which establishes the technical criteria for the development of rainwater harvesting systems from building roofs for non-potable purposes.

The rainwater systems **SAAP ECODEPUR® AQUAPLUVIA** allow the definition, by the end user, of the best solution for each project:

- Above ground system with basket filter incorporated;
- Underground system with basket filter incorporated;
- Underground system with external screening filter.

These systems may be complemented by a set of accessories to optimize the process for each case, taking into consideration the specific constraints of the installation.



RAINWATER SYSTEMS (SAAP) – TYPE OF RESERVOIRS

ABOVEGROUND SYSTEM WITH INTERNAL FILTER INCLUDED – RAC/SAAP

- Manufactured with anti-UV additive, by rotomolding system;
- Colour: black;
- Horizontal and vertical reinforcements duly located, which endow the structure with high resistance;
- Polyethylene Cover Ø 400 mm;
- Internal Filter Incorporated removable and easy to clean (particle retention > 1.2 mm).

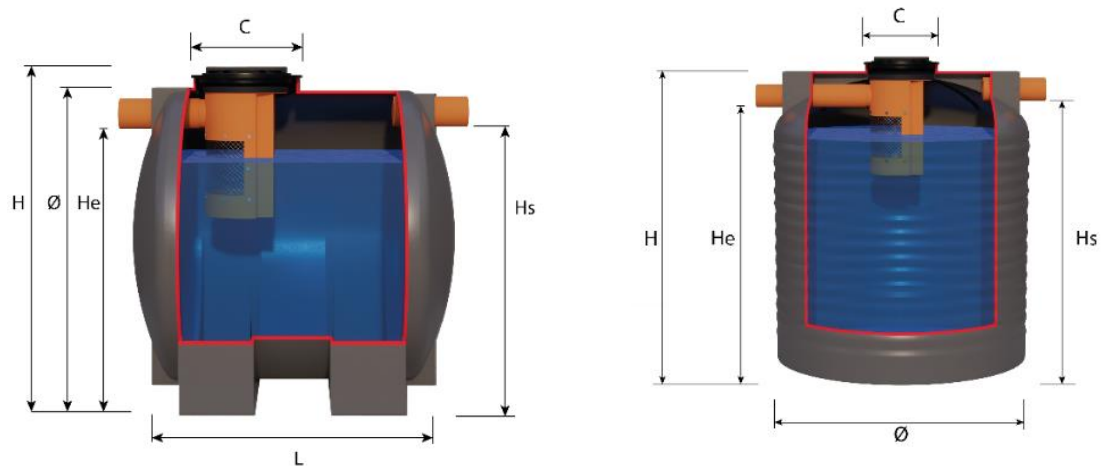

MODEL	TOTAL VOLUME (l)	Ø (mm)	L (mm)	H (mm)	AIR INLET (Ø)	PIPE INLET/BYPASS (mm)
SAAP ECODEPUR® AQUAPLUVIA RAC VT1.5	1.500	1.210	1.350	1.310	2"x 1"1/2	110
SAAP ECODEPUR® AQUAPLUVIA RAC VT2.0	2.000	1.530	-	1.655	2"x 1"1/2	110
SAAP ECODEPUR® AQUAPLUVIA RAC VT3.0	3.000	1.500	1.910	1.550	2"x 1"1/2	110
SAAP ECODEPUR® AQUAPLUVIA RAC VT4.0	4.000	1.890	-	1.940	2"x 1"1/2	110
SAAP ECODEPUR® AQUAPLUVIA RAC VT5.0	5.000	1.800	2.360	1.870	2"x 1"1/2	110

Images and reduced dimensions may be changed without prior notice.

RAINWATER SYSTEMS (SAAP) – TYPE OF RESERVOIRS

UNDERGROUND SYSTEM WITH INTERNAL FILTER INCLUDED - RSC/SAAP

- Manufactured with anti-UV additive, by rotomolding system;
- Colour: black;
- Horizontal and vertical reinforcements duly located, which endow the structure with high resistance;
- Polyethylene Cover Ø 400 (≤ 5.000 liters) and Ø 790 mm (> 5.000 liters ≤ 120.000 liters);
- Internal Filter Incorporated removable and easy to clean (particle retention > 1.2 mm);

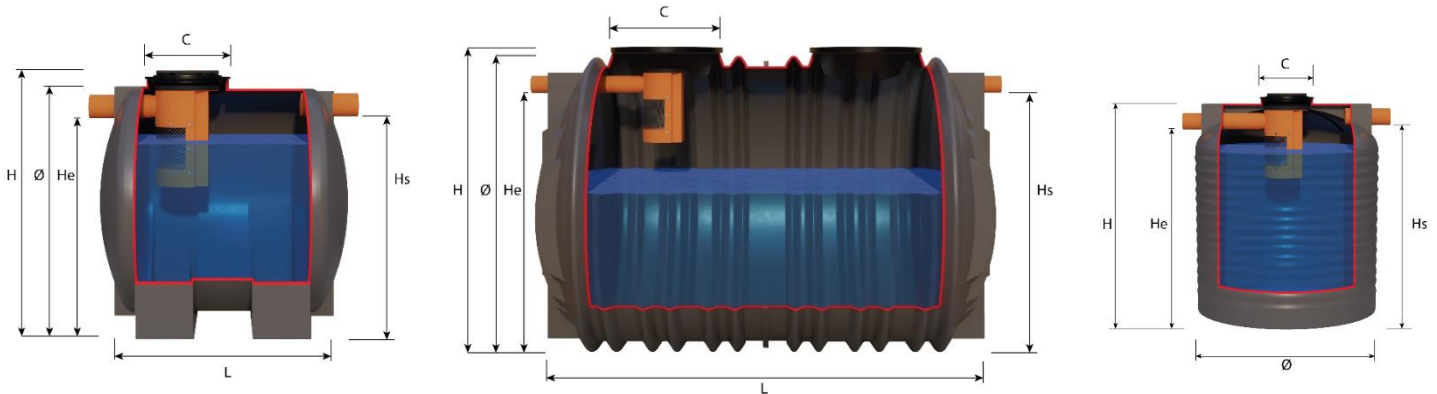

MODEL	TOTAL VOLUME (l)	Ø (MM)	L (MM)	H (MM)	AIR INLET (Ø)	PIPE INLET/BYPASS (mm)
SAAP ECODEPUR® AQUAPLUVIA RSC VT1.5	1.500	1.210	1.350	1.310	2"x 1"1/2	110
SAAP ECODEPUR® AQUAPLUVIA RSC VT2.0	2.000	1.530	-	1.655	2"x 1"1/2	110
SAAP ECODEPUR® AQUAPLUVIA RSC VT3.0	3.000	1.500	1.910	1.550	2"x 1"1/2	110
SAAP ECODEPUR® AQUAPLUVIA RSC VT4.0	4.000	1.890	-	1.940	2"x 1"1/2	110
SAAP ECODEPUR® AQUAPLUVIA RSC VT5.0	5.000	1.800	2.360	1.870	2"x 1"1/2	110
SAAP ECODEPUR® AQUAPLUVIA RSC VT10	10.000	2.190	3.440	2.265	90	125
SAAP ECODEPUR® AQUAPLUVIA RSC VT15	15.000	2.190	4.980	2.265	90	125
SAAP ECODEPUR® AQUAPLUVIA RSC VT20	20.000	2.190	6.520	2.265	90	125
SAAP ECODEPUR® AQUAPLUVIA RSC VT25	25.000	2.190	8.060	2.265	90	125
SAAP ECODEPUR® AQUAPLUVIA RSC VT30	30.000	2.190	9.600	2.265	90	125
SAAP ECODEPUR® AQUAPLUVIA RSC VT35	35.000	2.190	11.140	2.265	90	125
SAAP ECODEPUR® AQUAPLUVIA RSC VT40	40.000	2.190	12.680	2.265	90	125
SAAP ECODEPUR® AQUAPLUVIA RSC VT45	45.000	2.190	14.220	2.265	90	125
SAAP ECODEPUR® AQUAPLUVIA RSC VT50	50.000	2.980	8.520	3.050	110	125
SAAP ECODEPUR® AQUAPLUVIA RSC VT60	60.000	2.980	10.060	3.050	110	125
SAAP ECODEPUR® AQUAPLUVIA RSC VT70	70.000	2.980	11.600	3.050	110	125
SAAP ECODEPUR® AQUAPLUVIA RSC VT80	80.000	2.980	13.140	3.050	110	125
SAAP ECODEPUR® AQUAPLUVIA RSC VT90	90.000	2.980	14.680	3.050	110	125
SAAP ECODEPUR® AQUAPLUVIA RSC VT100	100.000	2.980	16.220	3.050	110	125
SAAP ECODEPUR® AQUAPLUVIA RSC VT110	110.000	2.980	17.760	3.050	110	125
SAAP ECODEPUR® AQUAPLUVIA RSC VT120	120.000	2.980	19.300	3.050	110	125

Images and reduced dimensions may be changed without prior notice.

RAINWATER SYSTEMS (SAAP) – TYPE OF RESERVOIRS

UNDERGROUND SYSTEM WITH EXTERNAL FILTER – RSFE/SAAP





- Manufactured with anti-UV additive, by rotomolding system;
- Colour: black;
- Horizontal and vertical reinforcements duly located, which endow the structure with high resistance;
- Polyethylene Cover Ø 400 (≤ 5.000 liters) and Ø 790 mm (> 5.000 liters ≤ 120.000 liters);
- External Filter to be defined.



MODEL	TOTAL VOLUME (l)	Ø (MM)	L (MM)	H (MM)	AIR INLET (Ø)	PIPE INLET/BYPASS (mm)
SAAP ECODEPUR® AQUAPLUVIA RSFE VT1.5	1.500	1.210	1.350	1.310	2"x 1"1/2	110
SAAP ECODEPUR® AQUAPLUVIA RSFE VT2.0	2.000	1.530	-	1.655	2"x 1"1/2	110
SAAP ECODEPUR® AQUAPLUVIA RSFE VT3.0	3.000	1.500	1.910	1.550	2"x 1"1/2	110
SAAP ECODEPUR® AQUAPLUVIA RSFE VT4.0	4.000	1.890	-	1.940	2"x 1"1/2	110
SAAP ECODEPUR® AQUAPLUVIA RSFE VT5.0	5.000	1.800	2.360	1.870	2"x 1"1/2	110
SAAP ECODEPUR® AQUAPLUVIA RSFE VT10	10.000	2.190	3.440	2.265	90	125/160/200
SAAP ECODEPUR® AQUAPLUVIA RSFE VT15	15.000	2.190	4.980	2.265	90	125/160/200
SAAP ECODEPUR® AQUAPLUVIA RSFE VT20	20.000	2.190	6.520	2.265	90	125/160/200
SAAP ECODEPUR® AQUAPLUVIA RSFE VT25	25.000	2.190	8.060	2.265	90	125/160/200
SAAP ECODEPUR® AQUAPLUVIA RSFE VT30	30.000	2.190	9.600	2.265	90	125/160/200
SAAP ECODEPUR® AQUAPLUVIA RSFE VT35	35.000	2.190	11.140	2.265	90	125/160/200
SAAP ECODEPUR® AQUAPLUVIA RSFE VT40	40.000	2.190	12.680	2.265	90	125/160/200
SAAP ECODEPUR® AQUAPLUVIA RSFE VT45	45.000	2.190	14.220	2.265	90	125/160/200
SAAP ECODEPUR® AQUAPLUVIA RSFE VT50	50.000	2.980	8.520	3.050	110	125/160/200
SAAP ECODEPUR® AQUAPLUVIA RSFE VT60	60.000	2.980	10.060	3.050	110	125/160/200
SAAP ECODEPUR® AQUAPLUVIA RSFE VT70	70.000	2.980	11.600	3.050	110	125/160/200
SAAP ECODEPUR® AQUAPLUVIA RSFE VT80	80.000	2.980	13.140	3.050	110	125/160/200
SAAP ECODEPUR® AQUAPLUVIA RSFE VT90	90.000	2.980	14.680	3.050	110	125/160/200
SAAP ECODEPUR® AQUAPLUVIA RSFE VT100	100.000	2.980	16.220	3.050	110	125/160/200
SAAP ECODEPUR® AQUAPLUVIA RSFE VT110	110.000	2.980	17.760	3.050	110	125/160/200
SAAP ECODEPUR® AQUAPLUVIA RSFE VT120	120.000	2.980	19.300	3.050	110	125/160/200

Images and reduced dimensions may be changed without prior notice.

RAINWATER SYSTEMS (SAAP) – EXTERNAL FILTERS

MODEL	
<p>RAINWATER FILTER FOR ROOF GUTTER</p> <p>This rainwater filter for roof gutter is the ideal solution for rainwater reuse in existing buildings. It's just necessary to connect the inlet/outlet Ø110 and the materials separated are removed from the frontal opening. This model is recommended until a maxim surface roof 70 m2.</p>	
<p>EXTERIOR HIGH-CAPACITY FILTER – FGC1</p> <p>The rainwater exterior high-capacity filter with is supplied with an extension, to install directly in the ground, before the storage tank. This model has a maximum flow capacity of 1,5 L/s = 5,4 m³ of rainwater per hour.</p>	
<p>EXTERIOR HIGH-CAPACITY FILTER – FGC2</p> <p>The installation of this rainwater filter is recommended for big roof areas. It can be installed on a concrete structure at least 1.000 mm diameter, or in masonry constructed in situ. This model has a maximum flow capacity of 3 L/s = 10,8 m³ of rainwater per hour.</p>	
<p>EXTERIOR HIGH-CAPACITY FILTER – FGC3</p> <p>The installation of this rainwater filter is recommended for big roof areas. It can be installed on a concrete structure at least 1.200 mm diameter, or in masonry constructed in situ. This model has a maximum flow capacity of 4,5 L/s = 16,2 m³ of rainwater per hour.</p>	
<p>EXTERIOR HIGH-CAPACITY FILTER – FGC6</p> <p>The installation of this rainwater filter is recommended for big roof areas. It can be installed on a concrete structure at least 1.200 mm diameter, or in masonry constructed in situ. This model has a maximum flow capacity of 9 L/s = 32,4 m³ of rainwater per hour.</p>	

RAINWATER SYSTEMS (SAAP) – COMPLEMENTARY ACCESSORIES

ACCESSORY	
<p>ANTI-TURBULENCE ENTRY</p> <p>It allows a slow entrance inside the tank, reducing the inflow velocity, preventing the mixing of solids that can be settled inside the tank. This entrance is completely assembled inside the tank and can be in diameters 110 mm, 125 mm or 160 mm.</p> <p>This accessory can be applied inside tanks with volume $\geq 10 \text{ m}^3$, as long as there is no internal filter.</p>	
<p>SIPHON FOR BY-PASS</p> <p>The siphon prevents smells to come out of the tank. This siphon is completely assembled inside tank and can be in diameters 110 mm, 125 mm or 160 mm.</p>	
<p>ANTI-RODENTS BARRIER</p> <p>The anti-rodent's barrier prevents the entrance of rodent inside the tank.</p>	
<p>ECODEPUR[®] PLUVIA SMARTBOX – INTELLIGENT WATER REUSE MANAGEMENT SYSTEM</p> <p>The module ECODEPUR[®] PLUVIA SMARTBOX is an intelligent water reuse management system, which allows the control, command for pressurization of the water, including an automatic switch from the water supply. This system is optimized to use all the rainwater collected inside the tank. If there is no rainwater to be used, it automatically switches the water supply for potable water.</p>	
<p>PUMP SUBMERSIBLE FOR SIMPLE SYSTEM WATER REUSE</p> <p>For direct water uses, such as irrigation, a submersible electric pump with minimum level protection through an attached float can be supplied. This allows the suction to be made from the intermediate area of the tank, thus avoiding the suction of floating solids, such as pollen and other suspended particles, as well as of heavier solids, such as sand, that tend to settle in the bottom of the tank.</p>	

INSTALATION

Above ground reservoirs must be installed on a solid and levelled base.

ECODEPUR® Underground Water Tank PE, Type RS installation should follow the recommendations of the installation instructions document, **Installation PE Reactors/Tanks (< 10.000 L).**

ECODEPUR® Underground Water Tank PE, Type RS installation should follow the recommendations of the document supplied **Installation PE Reactors/Tanks (Ø 2.190 or Ø2.980).**

In case of any doubt do not hesitate to contact our technical services.

ECODEPUR® will not be responsible if there are clear indications of poor installation or misuse of the equipment.

MAINTENANCE

Due to the characteristics of the equipment, the maintenance is simple, resumed to the periodic removal of solids from the bottom of the reservoir or from the filter.

It's also recommended a visual inspection of the inlet and outlet pipes, to make sure there is no clogging, as well as the tank's covers.

COMPONENT	MAINTENANCE FREQUENCY
FILTERS	Inspection and cleaning - semi-annual
PIPES DISCHARGE	Inspection and cleaning - semi-annual
SYSTEM'S DISINFECTION	Inspection – monthly Maintenance – annual
PUMPING SYSTEMS	According to supplier's recommendations
CONTROL UNITS	Inspection – semi-annual Maintenance – annual
PIPES AND REMAINING ACCESSORIES	Inspection - annual