

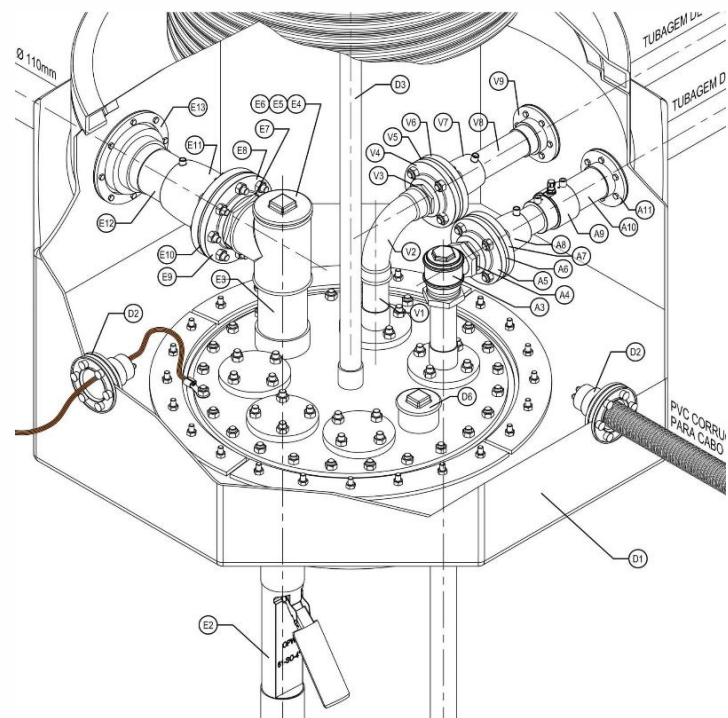



Rev.1\_14.10.15

# BASE SUMP TANK

ECODEPUR<sup>®</sup> ECO BST



 Z. I. Casal dos Frades, 68  
2435-661 Seiça - Ourém

 T. +351 249 571 500  
F. +351 249 571 501

 W. [www.ecodepur.pt](http://www.ecodepur.pt)  
@. [geral@ecodepur.pt](mailto:geral@ecodepur.pt)



## INTRODUCTION

**ECODEPUR® ECO BST and ECO BST PLUS** are Base Sump Tanks, completely tight, used directly in Oil tanks Manholes. Provides a direct access to equipment's, such as pumps, and offer a clean and dry area. They serve as a liquid tight isolation chamber, preventing ground water from entering and any leaking product from escaping into the environment.

The raw material used (Linear Polyethylene) was tested by an independent entity, guaranteeing high mechanical resistance and corrosion protection.

The equipment production under controlled conditions, the use of quality raw materials and the finished product inspection, in accordance with the demands of ISO Standard 9001, guarantee the final product quality.

ECODEPUR® Eco BST and Eco BST PLUS have 5 Year Guarantee against any manufacturing defects.

## FEATURES

- To Use directly in the Oil Tank manhole;
- Larger Areas, Provide easy and Safety installation;
- Octagonal, allowing several connections sides;
- Provides a total secure solution, avoiding environmental contamination;
- Height adjustment;
- One or Two-Piece Tank Sumps;
- High mechanical resistance and corrosion protection;
- Light and easy to install and maintain;
- Totally watertight;
- Easy access to inspection;
- Without visual impact;
- Low cost.

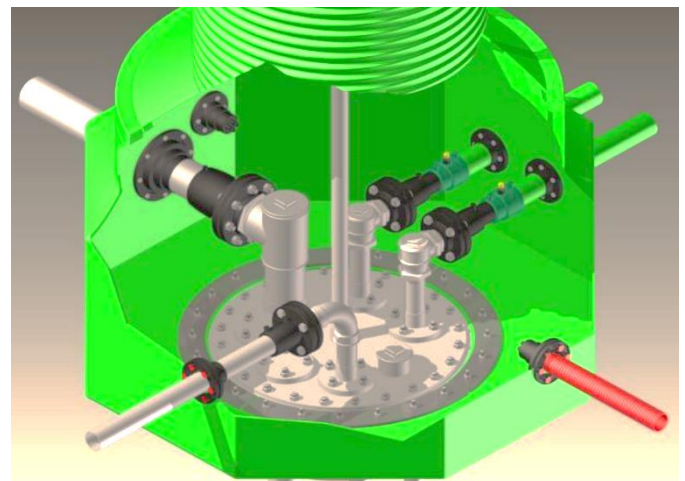

## DIMENSIONS

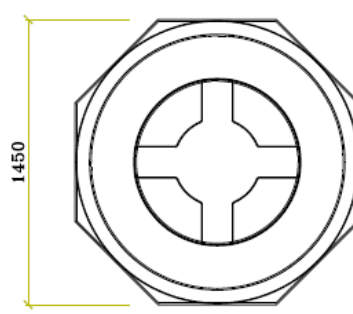
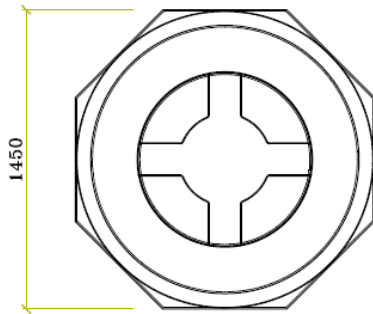
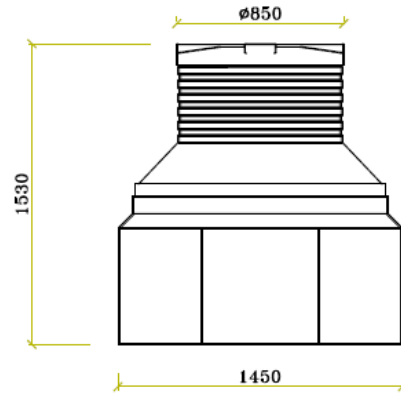
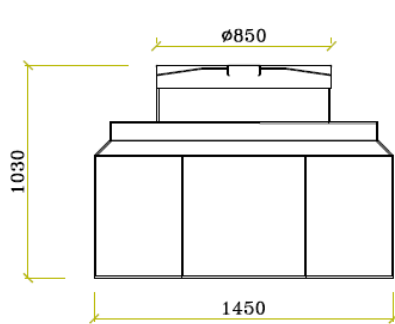

**ECO BST**

**ECO BST PLUS**

REF.	TYPE	L (mm)	H (mm)	C (mm)	WEIGHT (kg)
PR.ST.2.021	ECO BST	1.450	1.015	840	60
PR.ST.2.022.P	ECO BST PLUS	1.450	1.555	840	80

Images and dimensions may be changed without notice.

## INCLUDED ACCESSORIES

BASE SUMP TANK, ECODEPUR<sup>®</sup> ECO BST and BST PLUS.

### CONNECTION ACCESSORIES, ECODEPUR ECO BST PLUS



**Connection Accessories, ECODEPUR<sup>®</sup>** allows easy and safety connection between the Two Pieces of the **ECODEPUR<sup>®</sup> ECO BST PLUS**.

Includes:

- Metal segment
- Rubber profile
- Screws

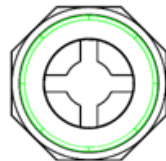
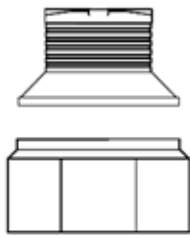

### COVER, ECODEPUR ECO BST and BST PLUS

**ECODEPUR<sup>®</sup> ECO BST and PLUS** includes a Polyethylene High mechanical resistance Cover.

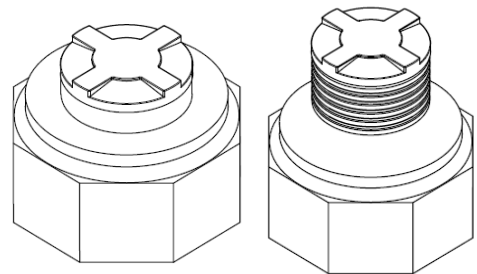
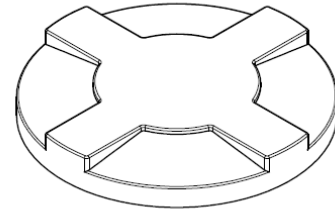

## OPTIONAL ACCESSORIES

BASE SUMP TANK, ECODEPUR<sup>®</sup> ECO BST and ECO BST PLUS.

### ENTRY BOOTS, ECODEPUR BUCIN

**Entry Boots, ECODEPUR<sup>®</sup>** allows a safety and flexible connection between the Pipe and the **BASE SUMP TANK, ECODEPUR<sup>®</sup> BST and BST PLUS**.

ECODEPUR<sup>®</sup> offer a complete line of sizes, from 1" up to 4"



REF.	TYPE	DIMENSIONS
PR.MPA.32.500	ECODEPUR <sup>®</sup> BUCIN 30 PTM	1"
PR.MPA.32.501	ECODEPUR <sup>®</sup> BUCIN 45 PTM	1 ½ "
PR.MPA.32.502	ECODEPUR <sup>®</sup> BUCIN 60 PTM	2 "
PR.MPA.32.503	ECODEPUR <sup>®</sup> BUCIN 75 PTM	2 ½ "
PR.MPA.32.504	ECODEPUR <sup>®</sup> BUCIN 90 PTM	3 "
PR.MPA.32.505	ECODEPUR <sup>®</sup> BUCIN 110 PTM	4 "

Images may be changed without notice.