



Rev.0_25.10.24

PREFABRICATED LIFT STATIONS

ECODEPUR[®] ECO

PREFABRICATED LIFT STATIONS ECODEPUR® ECO

Prefabricated Lift Stations ECODEPUR® ECO are complete water collection and lifting station, ready for installation. They are designed and sized according to the specific type of each application, aiming to optimize their operation and achieve pre-established goals safely and reliably.

Comprising a polyethylene tank, equipped with pumps suitable for the type of water to be lifted, a control panel, and level switches. The pumps are installed using dual guides with automatic coupling to a discharge base fixed to the bottom of the lift station, and compression piping made of plastic materials.

They are the ideal solution when water and/or effluents need to be pumped to a level higher than the collection point, or when gravity flow is not possible.

The electromechanical equipment has CE marking in accordance with current legislation.

APPLICATION

These lift stations should be used for:

- Pumping urban wastewater;
- Pumping raw or clean water.

MAIN CHARACTERISTICS

Depending on the size of the lift station, various pumps may be used, with sizing determined on a case-by-case basis according to the client's specifications:

- Liquid temperature: max. 40°C;
- Zero visual impact;
- Negligible noise and vibrations;
- Ease and speed of installation;
- High mechanical and chemical resistance due to the reservoir's construction material;
- Simplicity of operation and maintenance;
- Automatic operation.

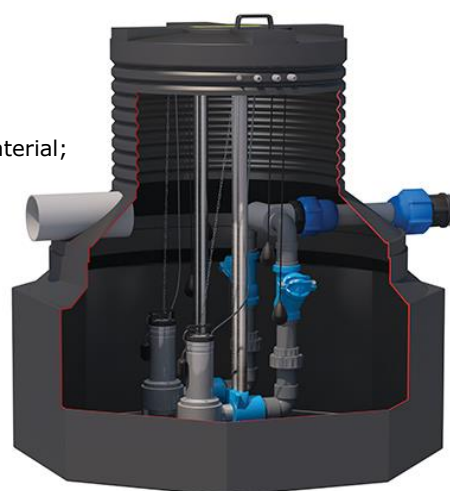

DIMENSIONS

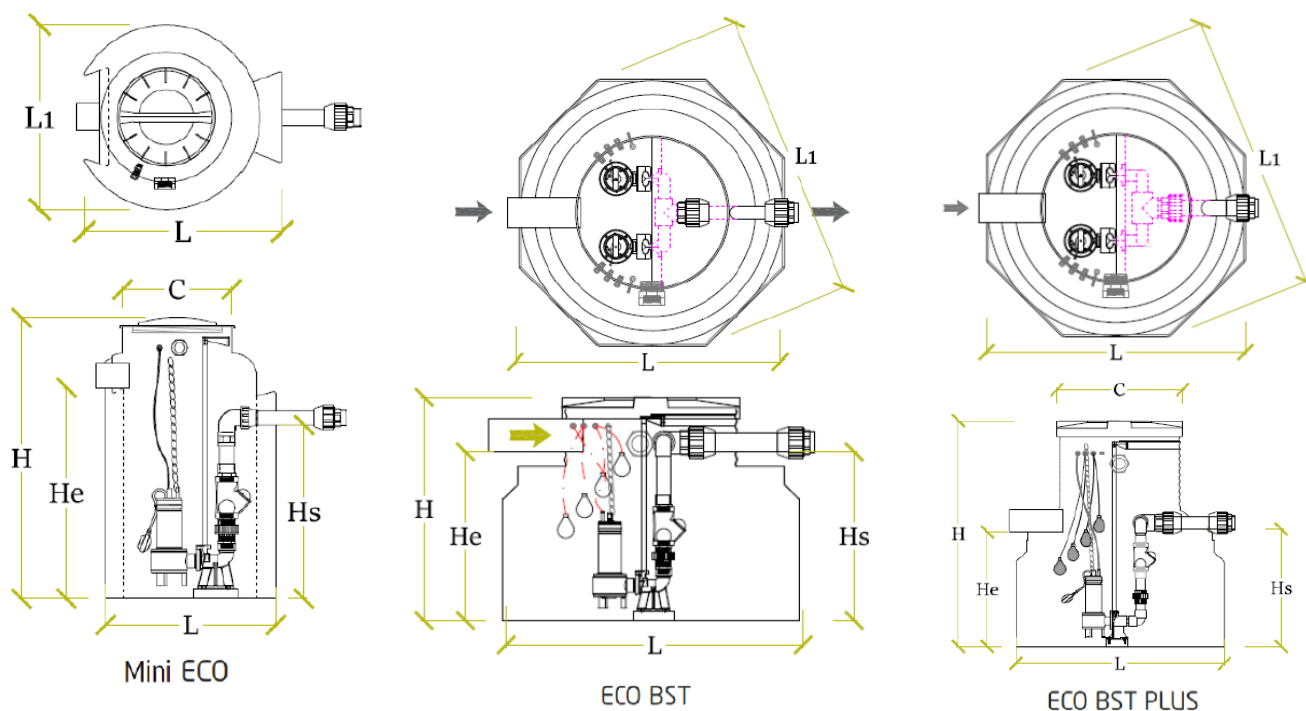

MODELO	L (mm)	L1 (mm)	ALTURA (mm)	VOLUME (l)	He (mm)	Hs (mm)	C (mm)	WITH CHECK VALVE INSIDE THE SUMP	PESO (Kg)	WITH OPTIONAL GATE VALVE ¹
Mini ECO	765	710	1.215	500	955	795	400	DN50	50	DN50
ECO BST	1.450	1.550	1.085	1.100	820	820	820	DN50	75	DN80
ECO BST PLUS	1.450	1.550	1.550	1.500	820	820	820	DN50	95	DN80

¹ TO BE INSTALLED IN A CONCRETE BOX TO BE CARRIED OUT BY THE CUSTOMER

COMPOSITION

ECODEPUR® Mini ECO Lift Stations complete and ready to install, with check valves mounted on the inside and gate valve on the outside (Optional):

- One (1) pumping well made from Polyethylene using a rotomolding system, which translates to high mechanical strength and corrosion resistance;
- One (1) submersible electric pump, model Domo;
- One (1) lowering and lifting device, with a settling base;
- One (1) ball check valve, DN 50 FFD, installed inside the pumping well;
- One (1) electrical control panel for the electric pump, with protection by a minimum level float – Mini lift station;
- One (1) DN50 FFD gate valve (OPTIONAL) to install outside the pumping well.

ECODEPUR® ECO BST and ECODEPUR® ECO BST PLUS Lift Station, complete and ready to install, with check valves mounted on the inside and gatevalve on the outside (Optional):

- One (1) pumping well made from Polyethylene using a rotomolding system, which translates to high mechanical strength and corrosion resistance;
- Two (2) submersible electric pumps, model Domo;
- Two (2) lowering and lifting devices, with a settling base;
- Two (2) ball check valves, DN 50 FFD, installed inside the pumping well;
- Four (4) Pear-type level switches, mercury-free;
- One (1) electrical control panel for switching and alternation of the electric pumps;
- One (1) DN50 FFD gate valve (OPTIONAL) to install outside the pumping well.

OPERATION

The **ECODEPUR® Mini ECO Lift Station** is controlled by the electric control panel for the pump (single-phase or three-phase) with direct start and protection against water shortage through a pear-type level float.

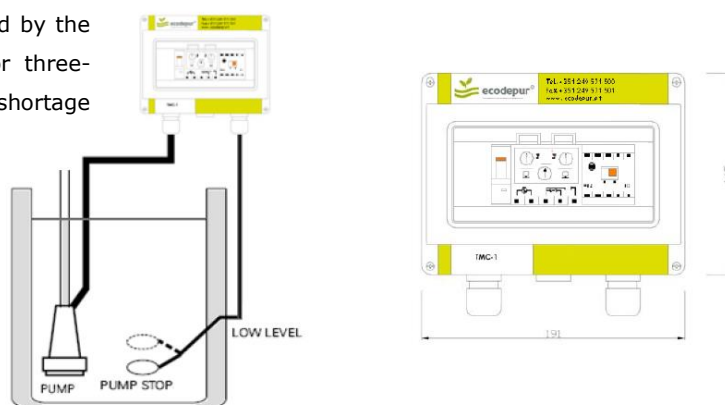

The **ECODEPUR® ECO BST and ECODEPUR® ECO BST PLUS Compact Lift Station** is controlled by the EPIC 2D electrical panel, featuring control and protection for two submersible pumps (single-phase or three-phase) with automatic alternation, managed by four float-type level switches, and it can also be controlled by an analogue probe (for example, a piezometric sensor).

Each float corresponds to an operating level:

- **Stop** (protection for the pumps against dry running);
- **Start / Alternation** (alternating start of each pump: either pump 1 starts or pump 2 starts);
- **Boost** (if the first pump is insufficient, the second pump starts, to have both pumps working);
- **Alarm** (if both pumps are insufficient to empty the station, the alarm is triggered).

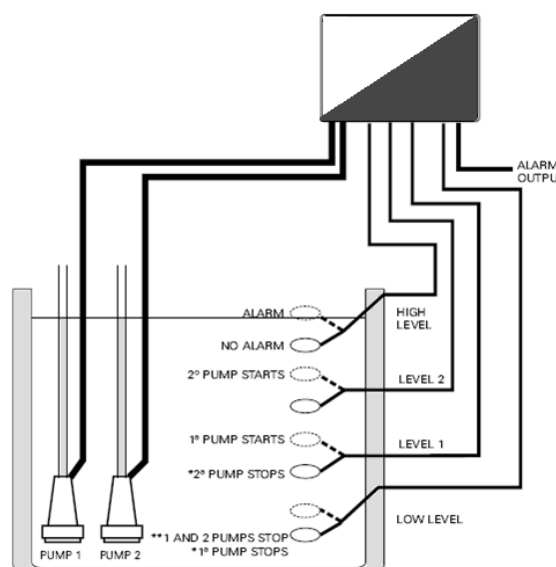

The floats are powered by a low safety voltage (2.7 V) to prevent the risk of electric shock in case of damage, and the pumps are protected by electronic overload relays.

This panel also has the following features:

- 2 buttons to switch between manual and automatic mode;
- Activity indicator light for the panel;
- LCD panel displaying status messages and alarms;
- Main cut-off switch with door lock;
- Protection and warning when maximum and minimum voltage values are reached;
- Protection and warning when maximum and minimum current values are reached;
- Detection and warning of phase loss;
- Protection against dry running with minimum current and $\cos \Phi$ reading;
- Alarm indication for maximum and minimum water levels;
- Self-learning function;
- Outputs for replicating the alarm signal (2 outputs 12 VDC + 1 output 240 VAC);
- All control elements are low voltage.

SPECIFICATIONS

FEATURE	VALOR
Voltage	230 / 400 VAC – 50 Hz
Permissible voltage variations	+/- 10%
Maximum Power	4,0 kW (400 V) – 1,5 kW (220 V)
Level switches voltage	2,7 VDC / 50 mAmp.
Level switches and alarm terminals	1,5 mm²
Installation	Wall-mounted by fastening forks
Weight EPIC2 230D/400D	3 / 6 kg
Protection	IP55
Working Temperature	-5°C / + 50°C
Maximum Relative Humidity	50% a 40°C without condensation

DIMENSIONS

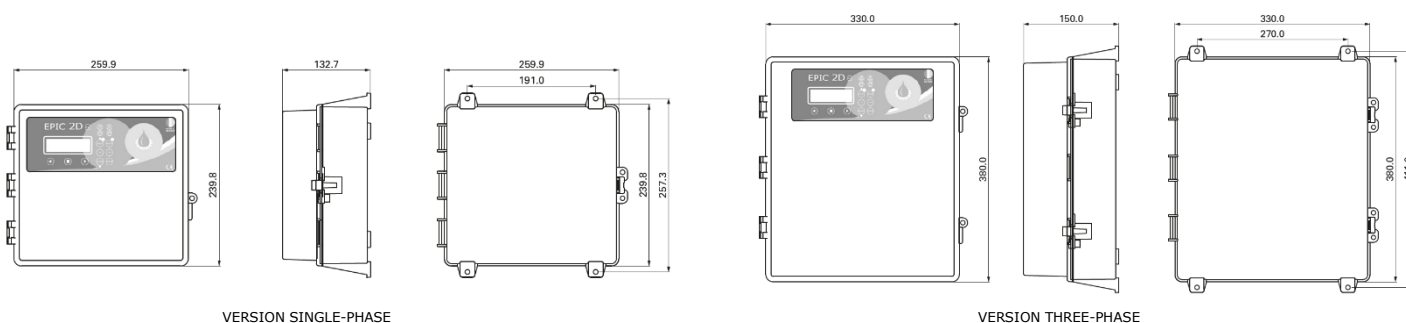

MATERIALS

The pumping wells are manufactured from UV-stabilized polyethylene using a rotomolding system, featuring a ring structure and internal structural reinforcements uniformly distributed throughout their length, which results in high mechanical resistance and insensitivity to corrosion.

The interior and exterior welds of the modules, piping, and fittings are completely executed by extrusion, using the best available technologies, under ISO 9001 controlled conditions, and with material of the same nature.

Insensitivity to corrosion phenomena was assessed by the Laboratório Nacional de Engenharia Civil (LNEC) – Departamento de materiais e o Instituto Científico Tecnológico de Polímeros (ICTPOL – Instituto Superior Técnico) - Test bulletin B 111 NMO 07.

The mechanical resistance, structural behaviour and watertightness tests were carried out in cooperation with AIMPLAS – Instituto Tecnológico del Plástico (Notified Body No. 1842 – Directive 89/106/CEE – Informe AT – 0699/11.

SAFETY RECOMMENDATIONS

ELECTRICAL SAFETY

To ensure proper maintenance of equipment and electrical panels, the next recommendations must be followed:

- Always turn off the main power supply to equipment before performing any work on it;
- Do not connect the equipment before all protective devices have been installed;
- Notify supervisors if an electrical protection system is out of service;
- Only specialized and trained personnel may perform work inside panels and control boards of electrical equipment;
- Record and report any anomaly in electric motors, such as temperature, vibrations, noise, etc.
- All drivers or live parts must be properly insulated;
- During the assembly and maintenance of electrical equipment, always follow the safety standards indicated in the technical manuals provided by the suppliers;
- Ensure proper grounding of all electrical equipment.

HEALTH SAFETY

- Prevent falls. All areas must be clean and unobstructed
 - Remove all forgotten or unnecessary objects;
 - Clean up spilled oils or pasta.
- Prevent infections and diseases
 - Use gloves when handling process components;
 - Take a shower and change clothes before going home;
 - Ensure vaccination against hepatitis B;
 - Avoid prolonged contact with water and biomass.

- Use common sense when moving or lifting loads
 - Use appropriate equipment for moving loads;
 - Use your legs to lift, never your back;
 - Do not run;
 - Use suitable stairs and walkways;
 - Whenever entry into the lift station is necessary, be aware of the risk of harmful gases and always wear a gas mask.

- Never work on equipment without first performing the shutdown procedures
 - Disconnect the manual and automatic circuits;
 - Cut off the main circuit.

CAUTIONS AND MAINTENANCE

The simplicity of the unit, combined with its automatic operation, allows its maintenance to be limited to a set of routine operations, the frequency of which will be dictated by normal operational practices.

The following is the minimum periodic maintenance schedule, and any other operations required in the manufacturers' manuals that may not be included here should also be considered.

It may be necessary to check some equipment more or less frequently, depending on the operator's assessment and experience.

For the maintenance of electrical or electromechanical equipment, it is advisable to consult the equipment documentation.

Weekly:

- Visually check the overall condition, namely:
 - Check for the occurrence of overflow in the discharger;
 - Check the correct alignment of the level floats;
 - Check for tripping in electrical protection mechanisms (thermal circuit breakers, differential breakers, etc.).

Monthly:

- Check the hydraulic operation of the system:
 - Occurrence of unusual noises during normal operation of the installation.
- Visually check the condition of pipes, joints, supports, etc;
- Check the safety systems:
 - Test the ground output of the differential circuit breaker using the appropriate button;
 - Test the thermal circuit breakers using the appropriate button;
- If necessary, clean any oils, greases, and solids accumulated on the level floats.

Annually:

- General cleaning of the tank;
- Check the pumps, specifically the condition of the impeller and bearings, and measure the consumption of the motor windings;
- Test the operation of the level floats and frequency relays.

INSTALLATION

The installation of the ECODEPUR® ECO Lift Station must follow the following installation instructions and the technical drawing attached:

1. The installation of the **ECODEPUR® Compact Lift Station tank in polyethylene (PE)** must follow the recommendations for the **Installation of Reactors/Tanks in Polyethylene (< 10.000 L)**, which are provided with the Product Catalogue;
2. In the case of supplying valves for installation outside the pumping well, it will be necessary to create a properly sized concrete valve box at the customer's expense. This box should not exert forces on the pumping well or the outlet pipes (if applicable). Access to the valves must also be ensured for proper handling;
3. The installation of the equipment must allow access and the presence of personnel in all necessary areas for performing maintenance operations on the equipment, under safe conditions;
4. Place the pumps inside the reservoir and connect them and the floats to the electrical panel according to the schematic (terminal strip); for single-phase pumps supplied with an external capacitor box, the pump cable must be disconnected from the capacitor box to be spliced so that the capacitor box can be installed in an appropriate location, preferably next to the electrical panel;
5. Ensure power supply to the control panel;

If in doubt, do not hesitate to contact our technical services.

WARRANTY

The equipment sold has a **two (2) years** warranty, covering any manufacturing defects.

ECODEPUR® – Tecnologias de Protecção Ambiental, Lda, will not be responsible if there are clear indications of poor installation, misuse (including the use of stable emulsions) or poor maintenance

CONTACTS

Zona Industrial Casal dos Frades,
Rua B, Lote 68
2435-661 Seiça - Ourém | PORTUGAL
geral@ecodepur.pt
+351 249 571 500
www.ecodepur.eu

WATER AND WASTEWATER TECHNOLOGIES

All technical data, indications, photographs or other information provided in our brochures and publications are provided for guidance only. ECODEPUR® reserves the right to modify the information presented without prior notice.